

## Adjusting the Rear Seats

### ■ Adjusting the Second Row Passenger's Seats

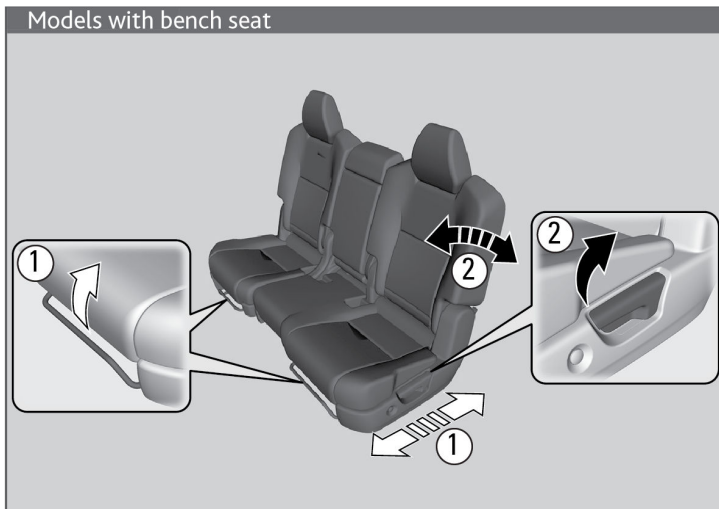

1. Horizontal Position Adjustment

2. Seat Back Angle Adjustment

## Models with captain seats



1. Horizontal Position Adjustment

2. Seat Back Angle Adjustment

**⚠ WARNING**

An unsecured seat or seat-back can move out of position or collapse without warning if there is sudden acceleration or stop or in a crash.

A seat or seat-back that suddenly moves or collapses can result in severe injury or death.

Always make sure all seats and seat-backs are securely locked into position before driving.

### ■ Third Row Seat Access

Pressing the button on the seat-back or seat cushion tilts the second row outer seat's seat-back forward. The whole seat slides forward.



Pulling up on the strap also tilts the seat-back forward.

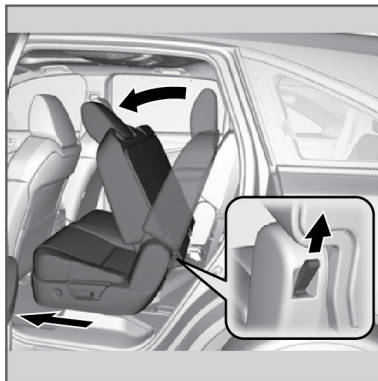

## ■ Folding Down the Rear Seats

Separately fold down the left and right halves of the second row seat to make room for cargo.

### Second Row Seat - Models with Bench Seat

1. Store the center seat belt.
2. Insert the latch plate into the slot on the side of the anchor buckle.
3. Retract the seat belt into the holder on the ceiling.
4. Lower the center head restraint to its lowest position. Put the armrest back into the seat back.

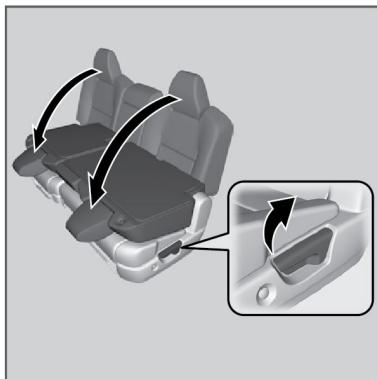

### All Models

5. Pull up on the seat back angle adjustment lever and fold down the seat-back.

To return the seat to the original position, pull up the seat-back in the upright position until it locks.

### Folding Down the Third Row Seat

Separately fold down the left and right halves of the third row seat to make room for cargo.

1. Pull the handle on the seat back fully. The head restraint tilts downward.
2. Push the seat back forward while pulling the handle.

To return the seat to the original position, pull the seat back up with the handle pulled, then push the head restraint up to its original position.

Make sure all items in the cargo area or items extending to the third row seats are properly secured. Loose items can fly forward if you have to brake hard.

