

### Airbags

Your vehicle is equipped with several types of airbags: front airbags, driver's knee airbag, side airbags, and side curtain airbags.

#### ■ Front Airbags (SRS)

The front SRS airbags inflate in a moderate-to-severe frontal collision to help protect the head and chest of the driver and/or passenger. They are housed in the center of the steering wheel for the driver and in the dashboard for the passenger. Both airbags are marked **SRS AIRBAG**.

**SRS** (Supplemental Restraint System) indicates that the airbags are designed to supplement seat belts, not replace them. Seat belts are the occupant's primary restraint system.

### Driver's Knee Airbag

The driver's knee SRS airbag inflates in a moderate-to-severe frontal collision to help keep the driver in the proper position and to help maximize the benefit provided by the vehicle's other safety features.

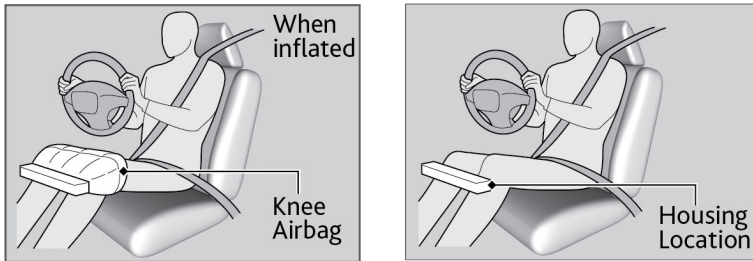

The driver's knee airbag is housed under the steering column. The airbag is marked **SRS AIRBAG**.

When the driver's front airbag inflates, the driver's knee airbag also inflates. Even if the collision is not severe enough to deploy the front airbag, the knee airbag may inflate alone.

### ■ Advanced Airbags

The passenger's airbag have advanced features to help reduce the likelihood of airbag related injuries to a smaller occupant.

The passenger's advanced airbag system has weight sensors.

We advise against allowing a child age 12 or under to ride in the passenger's seat.

However, **if you do allow a child age 12 or under to ride in the passenger's seat**, note that the system will automatically turn off the passenger's airbag if the sensors detect that the child is approximately 65 lbs (29 kg) or less.

For the passenger's advanced front airbag to work properly:

- Do not spill any liquid on or under the seat.
- Do not put any object under the passenger's seat.
- Make sure any objects are positioned properly on the floor. Improperly positioned objects can interfere with the advanced airbag sensors.
- An occupant should sit upright and wear their seat belts properly.
- Do not cover the passenger's side dashboard with a cloth, towel, cover, etc.

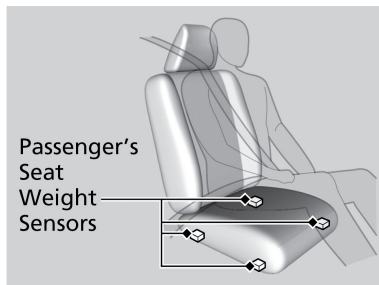

## ■ Side Airbags

The side airbags help protect the torso and pelvis of the driver or a passenger during a moderate-to-severe side impact. They are housed in the outside edge of the driver's and passenger's seat-backs. Both are marked **SIDE AIRBAG**.

When the sensors detect a moderate-to-severe side impact, the control unit signals the side airbag on the impact side to immediately inflate.

## ■ Side Curtain Airbags

Side curtain airbags help protect the heads of the driver and any passengers during a moderate-to-severe side impact. The side curtain airbags equipped in this vehicle are also designed to help reduce the likelihood of partial and complete ejection of vehicle occupants through side windows in crashes, particularly rollover crashes.

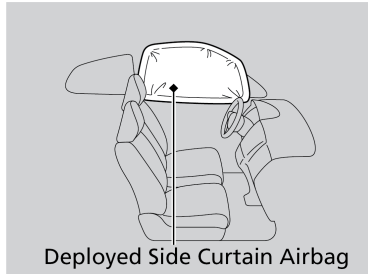
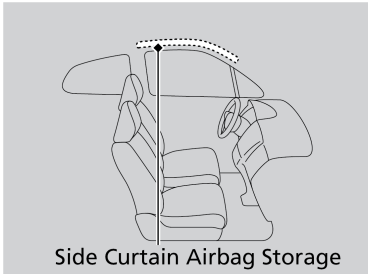

## SAFETY INFORMATION

---

The side curtain airbags are located in the ceiling above the side windows on both sides of the vehicle.

The side curtain airbag is designed to deploy in a rollover or moderate-to-severe side impact.

If the SRS control unit senses that your vehicle is about to roll over, it immediately deploys both side curtain airbags and activates both seat belt tensioners.

If the impact is on the passenger's side, the passenger's side curtain airbag deploys even if there is no occupant on that side of the vehicle.

To get the best protection from the side curtain airbags, occupants should wear their seat belts properly and sit upright and well back in their seats.

Do not attach any objects to the side windows or roof pillars as they can interfere with the proper operation of the side curtain airbags.

### When side curtain airbags deploy in a frontal collision

One or both side curtain airbags may inflate in a moderate-to-severe angled frontal collision.

### ■ Important Facts About Your Airbags

Airbags can pose serious hazards. To do their job, airbags must inflate with tremendous force. So, while airbags help save lives, they can cause burns, bruises, and other minor injuries, sometimes even fatal ones if occupants are not wearing their seat belts properly and sitting correctly.

**What you should do:** Always wear your seat belt properly, and sit upright and as far back from the steering wheel as possible while allowing full control of the vehicle. A passenger should move their seat as far back from the dashboard as possible.

Remember, however, that no safety system can prevent all injuries or deaths that can occur in a severe crash, even when seat belts are properly worn and the airbags deploy.

**Do not place hard or sharp objects between yourself and a front airbag.**

Carrying hard or sharp objects on your lap, or driving with a pipe or other sharp object in your mouth, can result in injuries if your front airbag inflates.

**Do not attach or place objects on the front and driver's knee airbag covers.**

Objects on the covers marked **SRS AIRBAG** could interfere with the proper operation of the airbags or be propelled inside the vehicle and hurt someone if the airbags inflate.

## ■ Airbag System Indicators

If a problem occurs in the airbag system, the SRS indicator comes on and a message appears on the Driver Information Interface.

### Supplemental Restraint System (SRS) Indicator

When the power mode is set to ON, the indicator comes on for a few seconds, then goes off. This tells you the system is working properly.

## SAFETY INFORMATION

If the indicator comes on at any other time, or does not come on at all, have the system checked by an authorized Acura NSX dealer as soon as possible. If you don't, your airbags and seat belt tensioners may not work properly when they are needed.

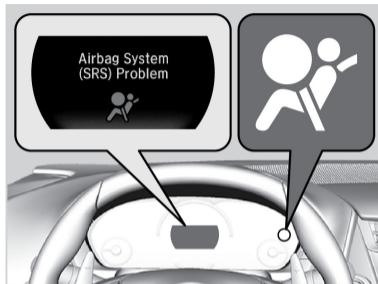

### **⚠ WARNING**

Ignoring the SRS indicator can result in serious injury or death if the airbag systems or tensioners do not work properly.

Have your vehicle checked by an authorized Acura NSX dealer as soon as possible if the SRS indicator alerts you to a possible problem.

### Passenger Airbag Off Indicator

The indicator comes on to alert you that the passenger's front airbag has been turned off. This occurs when the weight sensors detect 65 lbs (29 kg) or less, the weight of an infant or small child, on the seat.

Your vehicle is not recommended for child passengers. Never put a rear-facing child seat in this vehicle.

If you decided to disregard our recommendations and transport a small child, they should be properly restrained.

Objects placed on the seat can also cause the indicator to come on.

If the passenger's seat is empty, the passenger's front airbag will not deploy and the indicator will not come on.

If the indicator comes on with no passenger and no objects on the passenger's seat, or with an adult riding there, something may be interfering with the weight sensor, such as:

- An object hanging on the seat.
- An object pressing the rear of the seat-back.





## SAFETY INFORMATION

---

- The seat or seat-back is forced back against cargo on the rear trays or floor behind it.
- An object placed under the passenger's seat.

If none of these conditions exist, have your vehicle checked by an authorized Acura NSX dealer as soon as possible.

The passenger front airbag off indicator may come on and go off repeatedly if the total weight on the seat is near the airbag cutoff threshold.

## ■ Airbag System Components

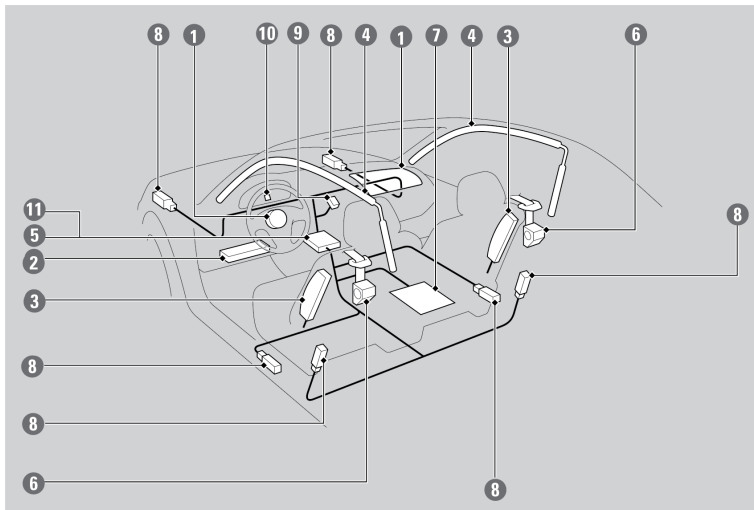

1. Two SRS (Supplemental Restraint System) front airbags. The driver's airbag is stored in the center of the steering wheel; the passenger's airbag is stored in the dashboard. Both are marked **SRS AIRBAG**.
2. Driver's knee airbag. The knee airbag is stored under the steering column. It is marked **SRS AIRBAG**.

## SAFETY INFORMATION

---

3. Two side airbags, one for the driver and one for a passenger. The airbags are stored in the outer edges of the seat-backs. Both are marked **SIDE AIRBAG**.
4. Two side curtain airbags, one for each side of the vehicle. The airbags are stored in the ceiling, above the side windows. The front and rear pillars are marked **SIDE CURTAIN AIRBAG**.
5. An electronic control unit that, when the power system is ON, continually monitors information about the various impact sensors, seat and buckle sensors, rollover sensor, airbag activators, seat belt tensioners, and other vehicle information. During a crash event the unit can record such information.
6. Automatic seat belt tensioners. In addition, the driver's and passenger's seat belt buckles incorporate sensors that detect whether or not the belts are fastened.
7. Weight sensors in the passenger's seat. The passenger's airbag will be turned off if the weight on the seat is approximately 65 lbs (29 kg) or less (the weight of an infant or small child).
8. Impact sensors that can detect a moderate-to-severe front or side impact.
9. An indicator on the dashboard that alerts you that the passenger's front airbag has been turned off.
10. An indicator on the instrument panel that alerts you to a possible problem with your airbag system or seat belt tensioners.

11. A rollover sensor that can detect if your vehicle is about to roll over and signal the control unit to deploy both side curtain airbags.

### ■ Airbag Care

You do not need to, and should not, perform any maintenance on or replace any airbag system components yourself. However, you should have your vehicle inspected by an authorized Acura NSX dealer in the following situations:

#### When the airbags have deployed

If an airbag has inflated, the control unit and other related parts must be replaced. Similarly, once an automatic seat belt tensioner has been activated, it must be replaced.

#### When the vehicle has been in a moderate-to-severe collision

Even if the airbags did not inflate, have an authorized Acura NSX dealer inspect the following: the weight sensors in the passenger's seat, seat belt tensioners, and each seat belt that was worn during the crash.

#### Do not remove or modify a seat without consulting an authorized Acura NSX dealer

This would likely disable or affect the proper operation of the weight sensors in the passenger's seat. If it is necessary to remove or modify a seat to accommodate a person with disabilities, contact an authorized Acura NSX dealer. For U.S. vehicles, call Acura Client Relations at 844-682-2872. For Canadian vehicles, call Acura Client Service at **1-888-9-ACURA-9** or

**1-844-9-MYNSX-9 (NSX-specific).**

### Child Safety

Each year, many children are injured or killed in vehicle crashes because they are either unrestrained or not properly restrained. In fact, vehicle crashes are the number one cause of death of children ages 12 and under.

To reduce the number of child deaths and injuries, every state, Canadian province and territory requires that children be properly restrained when they ride in a vehicle.

#### ■ Protecting Child Passengers

**Since this vehicle does not have a back seat, we recommend that you do not carry a child, age 12 or under, as a passenger.** This is because:

- An inflating front or side airbag can injure or kill a child sitting in the passenger's seat.
- A child in the passenger's seat is more likely to interfere with the driver's ability to safely control the vehicle.
- Statistics show that children of all sizes and ages are safer when they are properly restrained in a rear seat. Because this vehicle does not have a rear seat, we recommend that you do not carry a child age 12 or under in this vehicle.

- Any child who is too small to wear a seat belt correctly must be restrained in an approved child seat that is properly secured to the vehicle using the lap belt portion of the lap/shoulder belt.
- Never hold a child on your lap because it is impossible to protect them in the event of a collision.
- Never put a seat belt over yourself and a child. During a crash, the belt would likely press deep into the child and cause serious or fatal injuries.
- Never let two children use the same seat belt. Both children could be very seriously injured in a crash.
- Do not allow children to operate the doors, windows, or seat adjustments.
- Do not leave children, pets, or people needing assistance in the vehicle unattended, especially in hot weather when the inside of the vehicle can get hot enough to kill them. They could also activate vehicle controls, causing it to move unexpectedly.

To deactivate a lockable retractor, release the buckle and allow the seat belt to wind up all the way.

To remind you of the passenger's front airbag hazards and child safety, your vehicle has warning labels on the dashboard (U.S. models) and on the front visors. Please read and follow the instructions on these labels.

The National Highway Traffic Safety Administration and Transport Canada recommend that all children ages 12 and under be properly restrained in a rear

seat. Some states or provinces/territories have laws restricting where children may ride.

**Never put a rear-facing child seat in this vehicle.**

### **⚠ WARNING**

Children who are unrestrained or improperly restrained can be seriously injured or killed in a crash.

Any child too small for a seat belt should be properly restrained in a child seat.

A larger child should be properly restrained with a seat belt, using a booster seat if necessary.

### **⚠ WARNING**

Allowing a child to play with a seat belt or wrap one around their neck can result in serious injury or death.

Instruct children not to play with any seat belt.

#### **■ Protecting Infants**

An infant must be properly restrained in a rear-facing, reclining child seat until the infant reaches the seat manufacturer's weight or height limit for the seat, and the infant is at least one year old. **Because rear-facing child seats should not be used in this vehicle, you should never carry an infant in this vehicle.**

Rear-facing child seats should never be installed in a forward-facing position.

**⚠ WARNING**

Placing a rear-facing child seat in the passenger's seat can result in serious injury or death during a crash.

Never install a rear-facing child seat in this vehicle.

■ **Protecting Smaller Children**

Since this vehicle does not have a back seat, we recommend that you do not carry a child, age 12 or under, as a passenger.

This is because placing a forward-facing child seat in the passenger's seat can be hazardous, even with advanced front airbags that automatically turn the passenger's front airbag off.

If you choose to ignore our warnings and transport a small child in this vehicle, be sure to move the passenger seat as far to the rear as possible, and follow the instructions and guidelines in the following pages.

Educate yourself about the laws and regulations regarding child seat use where you are driving, and follow the child seat manufacturer's instructions.



## SAFETY INFORMATION

---

A child seat must be secured to the vehicle with the lap part of a lap/shoulder belt. A child whose seat is not properly secured to the vehicle can be endangered in a crash.

### **⚠ WARNING**

Placing a forward-facing child seat in the passenger's seat can result in serious injury or death if the front airbag inflates.

If you must place a forward-facing child seat in passenger's seat, move the vehicle seat as far back as possible, and properly restrain the child.

#### ■ **Selecting a Forward-facing Child Seat**

##### *Important consideration when selecting a child seat*

Make sure the child seat meets the following three requirements:

- The child seat is the correct type and size for the child.
- The child seat is the correct type for the seating position.
- The child seat is compliant with Federal Motor Vehicle Safety Standard 213 or Canadian Motor Vehicle Safety Standard 213.

#### ■ **Installing a Child Seat**

A child seat must be secured to the vehicle with the lap part of a lap/shoulder belt.

For your child's safety, when using a child seat installed using the vehicle's seat belt system, check that the seat is properly secured to the vehicle.

1. Move the passenger seat to the rearmost position.
2. Place the child seat on the passenger seat.
3. Route the seat belt through the child seat according to the seat manufacturer's instructions, and insert the latch plate into the buckle. Insert the latch plate fully until it clicks.
4. Slowly pull the shoulder part of the belt all the way out until it stops. This activates the lockable retractor.
5. Let the seat belt completely wind up into the retractor, then try to pull it out to make sure the retractor is locked. If you are able to pull the shoulder belt out, the lockable retractor is not activated. Pull the seat belt all the way out, and repeat steps 3– 5.

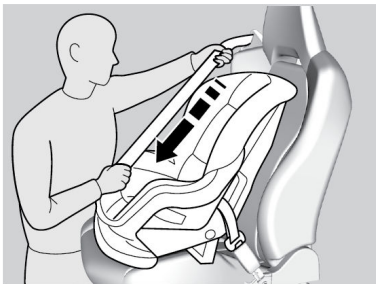
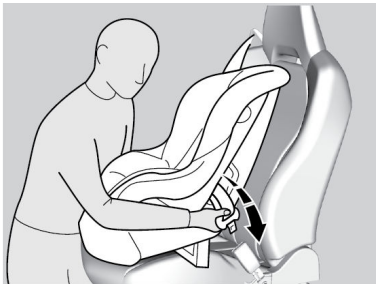

## SAFETY INFORMATION

---

6. Grab the shoulder part of the seat belt near the buckle, and pull up to remove any slack from the lap part of the belt. When doing this, place your weight on the child seat and push it into the vehicle seat.
7. Make sure the child seat is firmly secured by rocking it forward and back, and side to side; less than one inch of movement should occur near the seat belt.

A child seat that is not properly secured will not adequately protect a child in a crash and may cause injury to the child or another vehicle occupant.

To deactivate a lockable retractor, release the buckle and allow the seat belt to wind up all the way.

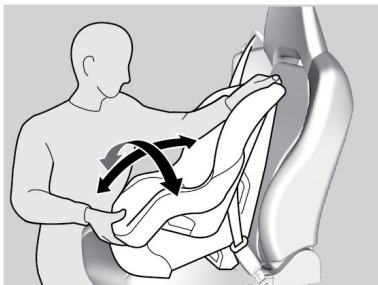
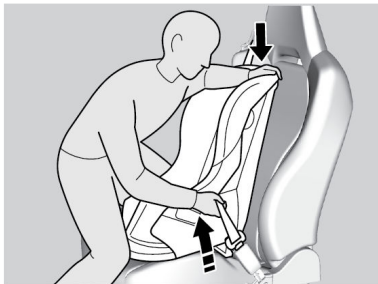

## ■ Adding Security with a Tether

A tether anchorage point is provided behind the passenger seat. A child seat with a tether can be installed, so long as the base of the child seat is secured using a seat belt.

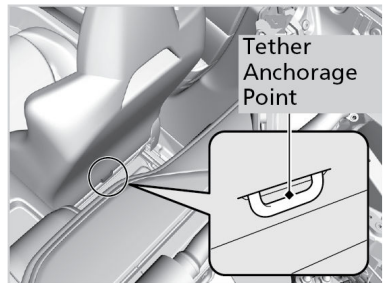

1. Move the seat forward.
2. Route the tether strap through the hole between the head restraint and seat-back. Make sure the strap is not twisted.
3. Secure the tether strap hook to the anchor.
4. Tighten the tether strap as instructed by the child seat manufacturer.
5. Move the seat to the rearmost position.

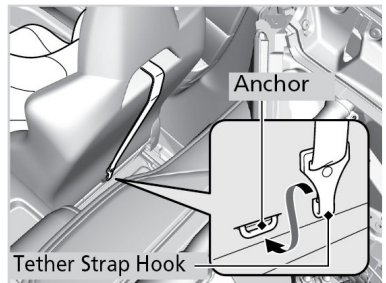

Since a tether can provide additional security to the lap/shoulder seat belt installation, we recommend using a tether whenever one is available.

### ■ Protecting Larger Children

Since this vehicle does not have a back seat, we recommend that you do not carry a child age 12 or under as a passenger. This is because children who have outgrown child seats are also at risk of being injured or killed by an inflating passenger's front airbag. If a larger child must ride in this vehicle, the following information may be useful when deciding when a child may ride in this vehicle and how to properly protect the child.

Have the child sit upright and all the way back, then ensure the following:

- The child's knees bend comfortably over the edge of the seat.
- The shoulder belt crosses between the child's neck and arm.
- The lap part of the seat belt is as low as possible, touching the child's thighs.
- The child can stay seated for the whole trip.



If a lap/shoulder belt cannot be used properly, position the child in a booster seat in the passenger's seating position. For the child's safety, check that the child meets the booster seat manufacturer's recommendations.

When installing a booster seat, make sure to read the instructions that came with it, and install the seat accordingly.

There are high- and low-type booster seats. Choose a booster seat that allows the child to wear the seat belt correctly.

Some U.S. states and Canadian provinces and territories require children to use a booster seat until they reach a given age or weight (e.g., 6 years or 60 lbs). Be sure to check current laws in the state or province, or territory where you intend to drive.

**⚠ WARNING**

Allowing a child age 12 or under to sit in the vehicle can result in injury or death if the passenger's front airbag inflates.

If a larger child must ride in the vehicle, move the vehicle seat as far to the rear as possible, have the child sit up properly and wear the seat belt properly, using a booster seat if needed.

## Safety Label Locations

Safety labels are in the locations shown. They warn you of potential hazards that can cause serious injury or death. Read these labels carefully.

If a label comes off or becomes hard to read (except for the U.S. dashboard label which may be removed by the owner), contact an authorized Acura NSX dealer for a replacement.

### Dashboard U.S. models only

**This Vehicle is Equipped with Advanced Air Bags**  
Even with Advanced Air Bags

Children can be killed or seriously injured by the air bags. Please read your Owner's Manual for the latest information on how to use your child and your passengers. See your Owner's Manual for more information about air bags. To be removed by owner only.

### Sun Visors U.S. models

**WARNING**  
EVEN WITH ADVANCED AIR BAGS

- For maximum safety protection in all types of crashes, you must always wear your safety belt.
- Do not install rear-facing child seats in any front passenger seat position.
- Do not sit or lean unnecessarily inside the air bag.
- Do not place any objects over the air bag or between the air bag and yourself.
- See the owner's manual for further information and explanations.

### Canadian models

**WARNING**

- Pour éviter des blessures graves en toutes circonstances, vous devez toujours porter votre ceinture de sécurité.
- N'installez jamais un siège pour enfants à l'arrière d'un véhicule avant d'être fixé au siège passager.
- N'installez aucun objet sur le dessus du siège ou entre le siège et vous-même.
- Ne placez rien sur l'air bag et ne vous appuyez pas sur l'air bag.
- Lisez le guide propriétaire pour de plus amples renseignements.

### High Voltage System Components U.S. models

**WARNING**  
**HIGH VOLTAGE**

- You can be killed or hurt.
- Do not remove this cover.
- No customer serviced parts inside.
- No customer serviced parts inside.

**ATTENTION**

**HIGH VOLTAGE**

- You can be killed or hurt.
- Do not disconnect, open, or take apart.

### Canadian models

**WARNING**  
**HAUTE TENSION**

- Vous pouvez être tué ou blessé.
- N'enlevez pas ce couvercle.
- Aucune pièce à l'extérieur n'est à l'intérieur.
- N'essayez pas de débrancher, ouvrir ou démonter.
- Ne déconnectez pas, n'ouvrez pas et ne démontez pas.

**ATTENTION**

**HAUTE TENSION**

- Vous pouvez être tué ou blessé.
- Ne déconnectez pas, n'ouvrez pas et ne démontez pas.

### Inverter Coolant Filler Tank Cap

### Air Conditioner System

U.S. models

**WARNING**

Flammable Refrigerant  
CAUTION: R-1234yf GAS IS EXTREMELY FLAMMABLE UNDER HIGH PRESSURE.  
TO BE SERVICED, USE ONLY QUALIFIED PERSONNEL.  
Follow instructions in the service manual.

**AIR CONDITIONER SYSTEM**  
REFRIGERANT: R-1234yf (HFC) (NON-FLAMMABLE)  
REC. CHARGE: MAX 0.455kg MIN 0.432kg  
OIL TYPE: ND-OL11 (POE)

TECH R-1234yf

Canadian models

### Engine Coolant Reserve Tank Cap