

■ Adjusting the Sound

Adjusting the Sound - Models with One Display

Press the SETUP button, and rotate the selector knob to select Sound Settings. Rotate the selector knob to scroll through the following choices.

- Bass
- Treble
- Fader
- Balance
- Speed-sensitive Volume Compensation



Adjusting the Sound - Models with Two Displays

1. Select Audio Menu, then select Sound Settings.
2. Select the Bass, Treble, Fader, Balance, Center^{*1}, Subwoofer, SVC (Speed-sensitive Volume Compensation) or DTS Neural Surround^{*1}.

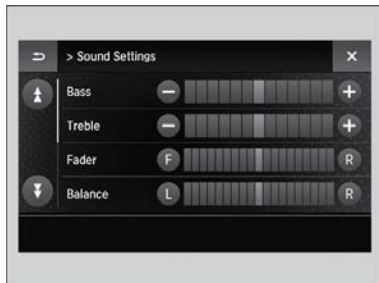

- Use +, - or other icons to adjust the setting.

On Demand Multi-Use Display™

Use the On Demand Multi-Use Display™ to operate the audio system.

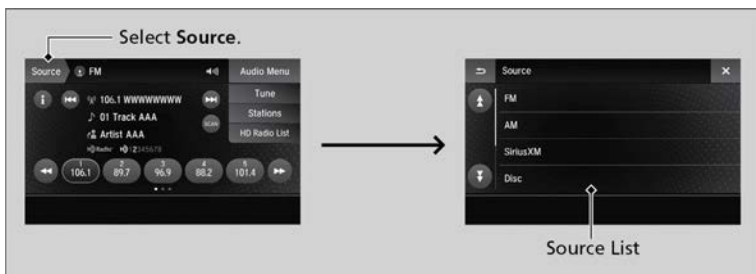

AcuraLink®

A subscription-based service that provides convenient features such as voice communication in case of emergency, online security, one-on-one operator assistance, and the transmission of important messages regarding your vehicle's status.

To subscribe to AcuraLink®, or to get more information about all of its features, contact an Acura dealer, or visit owners.acura.com (U.S.) or acura.ca (Canada).

■ AcuraLink® Connection

- Open the cover attached to the ceiling console.
 - Press the ASSIST button.
- You are connected to the AcuraLink operator.



AcuraLink® Assist*1

If your vehicle's airbags deploy or if the unit detects that the vehicle is severely impacted, your vehicle automatically attempts to connect to an operator. Your phone must be paired to the system and have good cellular connection. Visit owners.acura.com (U.S.) or www.acura.ca/owners/acuralink (Canada) for more information.



Apple CarPlay™

■ Models with Two Displays

If you connect an Apple CarPlay™-compatible iPhone® to the system via the USB port, you can use the information screen, instead of the iPhone® display, to make a phone call, listen to music, view maps (navigation), and access messages.

**1 - If equipped*
 Depending on use, Apple CarPlay™ can share certain vehicle information (e.g., vehicle location, speed, and other operating conditions) with the connected iPhone®. See Apple's privacy policy for details regarding Apple's use and handling of data uploaded by Apple CarPlay™. Use of Apple CarPlay™ is at user's own risk, and is subject to agreement to the Apple CarPlay™ terms of use, which are included as part of the Apple iOS terms of use. Apple CarPlay™ vehicle integration is provided "as is," and Acura cannot guarantee Apple CarPlay™ operability or functionality now or in the future due to, among other conditions, changes in Apple CarPlay™ software/Apple iOS, service interruptions, or incompatibility or obsolescence of vehicle-integrated hardware or software. See dealer for details. Only use Apple CarPlay™ when conditions allow you to do so safely. See your Owner's Manual at owners.acura.com (U.S.) or www.acura.ca (Canada) for further license and warranty terms.

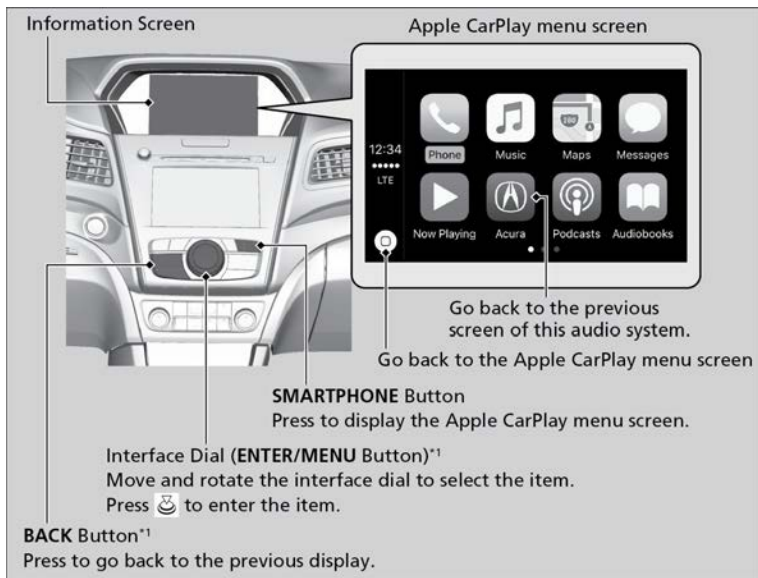

* 1: The operation methods may differ from your connected iPhone.

* Not available on all models

Phone: Access the contact list, make phone calls, or listen to voice mail.

Messages: Check and reply to text messages, or have messages read to you.

Music: Play music stored on your iPhone®.

Maps: Display Apple Maps and use the navigation function just as you would on your iPhone®.

Models with navigation system

Only one navigation system (pre-installed navigation or Apple CarPlay™) can give directions at a time. When you are using one system, directions to any prior destination set on the other system will be canceled, and the system you are currently using will direct you to your destination.

Android Auto™

Depending on use, Android Auto can share certain vehicle information (e.g., vehicle location, speed, and other operating conditions) with Google and its service providers. See Google privacy policy for details regarding Google's use and handling of data uploaded by Android Auto. Use of Android Auto is at user's own risk, and is subject to agreement to the Android Auto terms of use, which are presented to the user when the Android Auto application is downloaded to the user's Android phone. Android Auto vehicle integration is provided "as is," and Acura cannot guarantee Android Auto operability or functionality now or in the future due to, among other conditions, changes in Android Auto software/

■ Models with Two Displays

When you connect an Android phone to the audio system via the USB port, Android Auto™ is automatically initiated. When connected via Android Auto™, you can use the information screen to access the Phone, Google Maps (Navigation), Google Play Music, and Google Now functions. When you first use Android Auto™, a tutorial will appear on the screen.

We recommend that you complete this tutorial while safely parked before using Android Auto™.

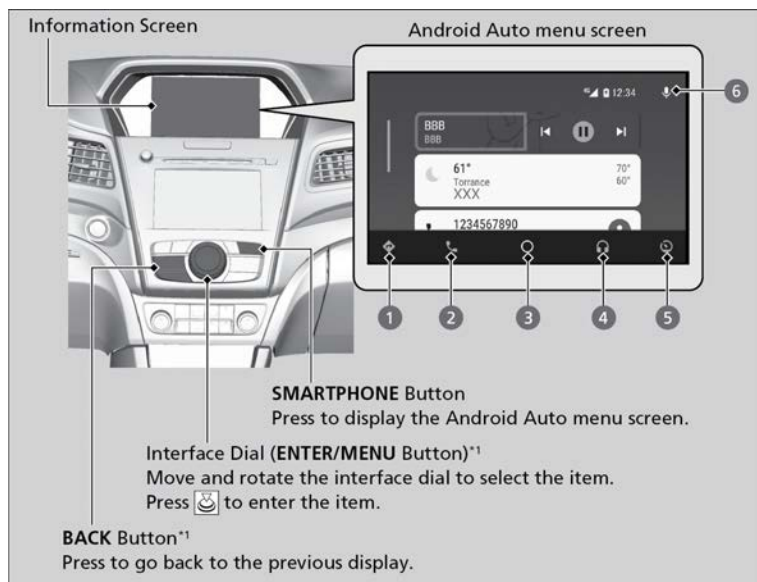

*1: The operation methods may differ from your connected Android phone.

- 1. Maps (Navigation):** Display Google Maps and use the navigation function just as you would with your Android phone. When the vehicle is in motion, it is not possible to make keyboard entries. Stop the vehicle in a safe location to undertake a search or provide other inputs.
- 2. Phone (Communication):** Make and receive phone calls as well as listen to voicemail.
- 3. Google Now (Home Screen):** Display useful information organized by Android Auto into simple cards that appear just when they're needed.

Android operating system, service interruptions, or incompatibility or obsolescence of vehicle-integrated hardware or software. See dealer for details. Only use Android Auto when conditions allow you to do so safely. See your Owner's Manual at owners.acura.com (U.S.) or acura.ca (Canada) for further license and warranty terms.

- Music and Audio:** Play Google Play Music and music apps that are compatible with Android Auto. To switch between music apps, press this icon.
- Go back to the previous screen of this audio system.**
- Voice:** Operate Android Auto with your voice.

FM/AM Radio

Play FM or AM radio stations.

■ Models with One Display

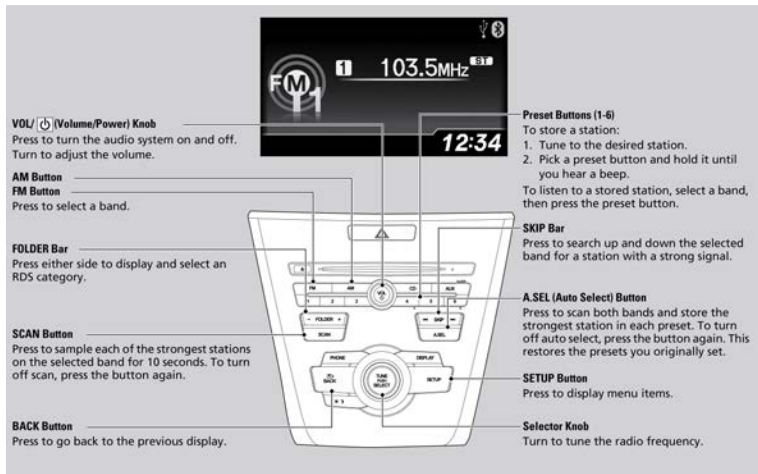

■ Models with Two Displays

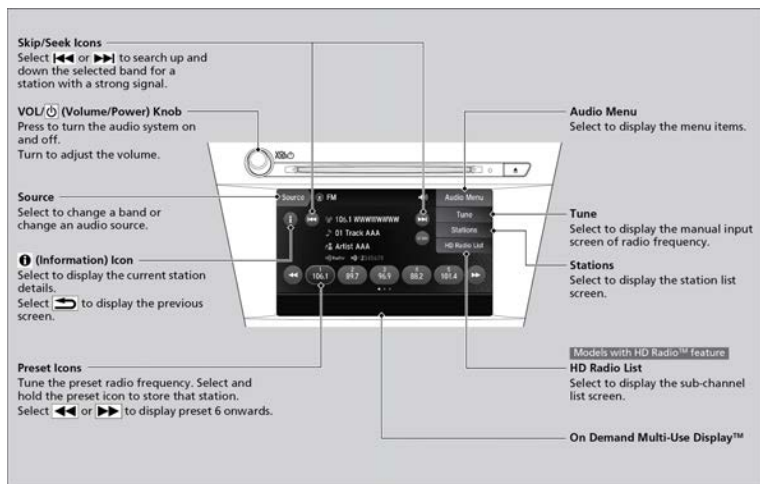
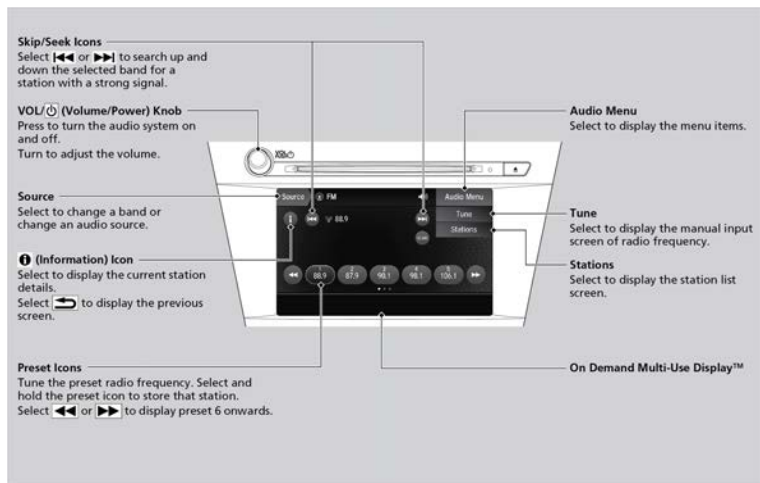

SiriusXM® *1

Available on a subscription basis only. For more information or to subscribe, contact your dealer, or visit www.sirius.com/subscribenow (U.S.) or www.sirius.ca/subscribe-now (Canada).

**1 - If equipped*

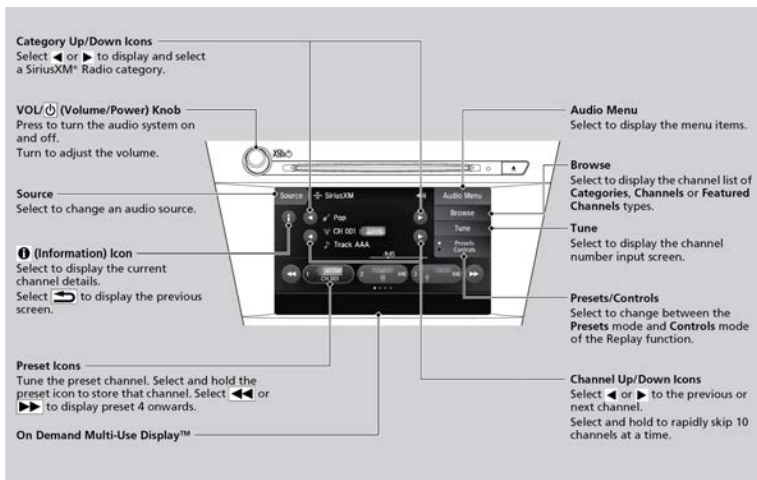

iPod®

Play and operate an iPod®*14 through the vehicle's audio system. Connect your device to the USB port (see USB Port).

■ Models with One Display

Connect the iPod® using your USB connector to the USB adapter cable, then press the AUX button.

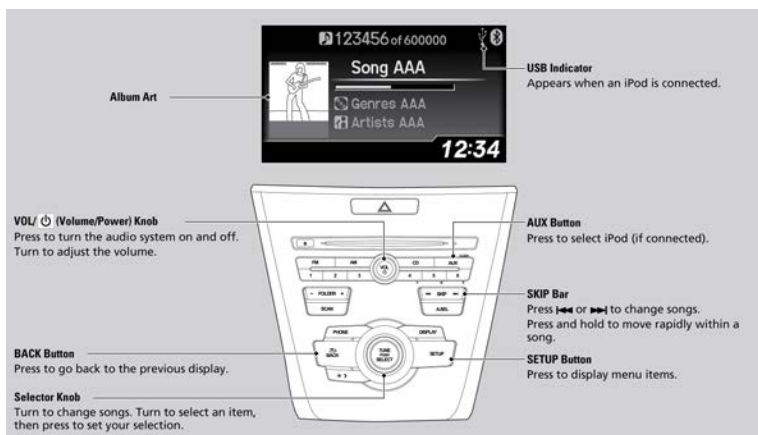

*14 - iPod and iPhone are trademarks of Apple, Inc.

■ Models with Two Displays

Connect the iPod using your USB connector to the USB port, then select the iPod mode.

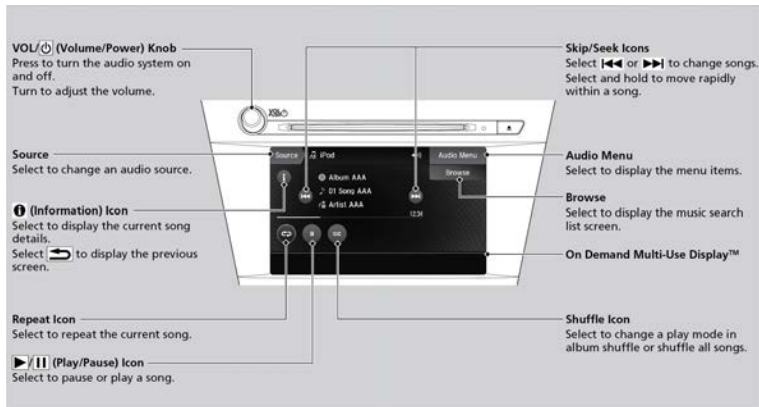

■ Searching for Music

Models with One Display

1. Press the selector knob to display the iPod® menu.
2. Select a Menu.
3. Press the selector knob to display the items on that menu.
4. Select an item.



Models with Two Displays

1. Select Browse.
2. Select the items on that menu.

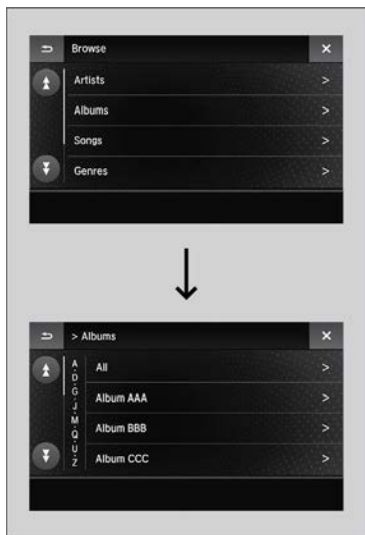

Pandora®*13

Your audio system allows you to listen to music from the Pandora® app on a compatible smartphone. This function is available when the phone is paired and connected to the vehicle's *Bluetooth*® HandsFreeLink® system, or with an iPhone®, you can connect using your USB cable to the USB port.

■ Models with One Display

Activate Pandora®, and connect the iPhone® using your USB connector to the USB adapter cable, then press the AUX button.

**13 - US models only, if equipped*

Applicable laws may prohibit the operation of handheld electronic devices while operating a vehicle. Launch streaming audio on your phone only when it is safe to do so.

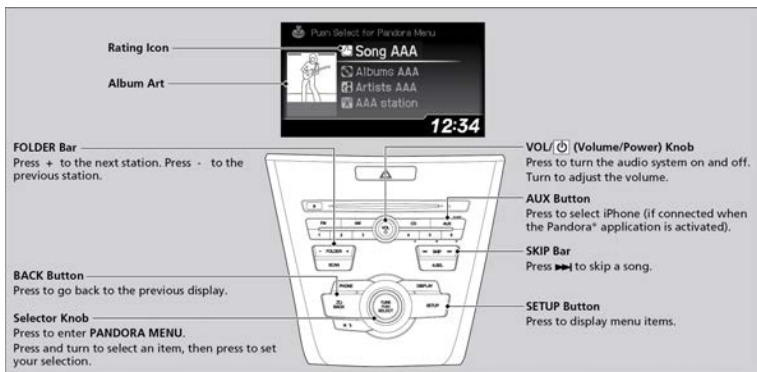

Models with Two Displays

Your audio system allows you to listen to music from the Pandora® app on a compatible smartphone. This function is available when the phone is paired and connected to the vehicle's *Bluetooth*® HandsFreeLink® (HFL) system, or with an iPhone®, you can connect using your USB cable to the USB port.

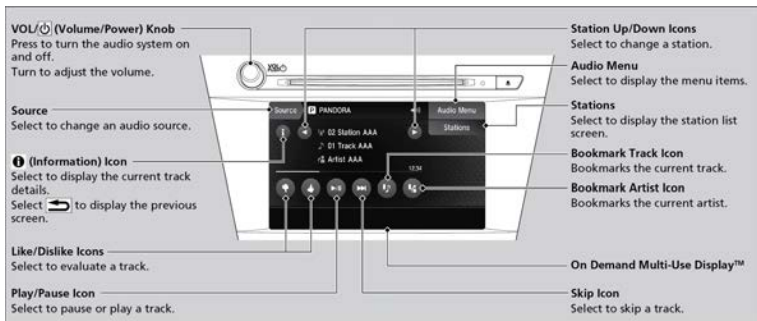

USB Flash Drive

Your audio system reads and plays sound files on a USB flash drive in either MP3, WMA, or format. Connect your USB flash drive to the USB port .

Models with One Display

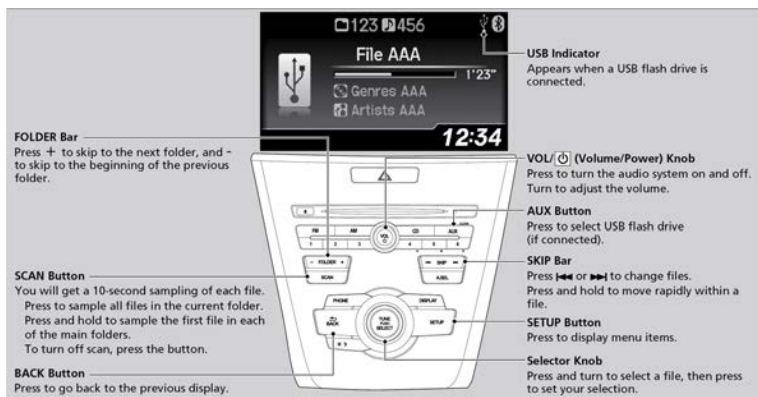

*1 Only AAC format files recorded with iTunes are playable on this unit.

* Not available on all models

Models with Two Displays

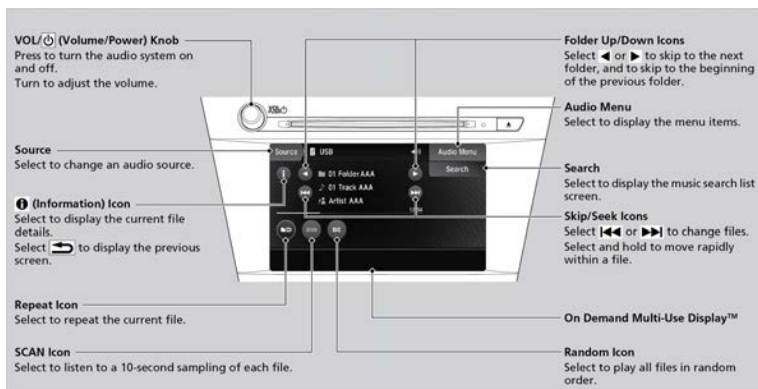

*1 Only AAC format files recorded with iTunes are playable on this unit.

* Not available on all models

Searching for Music

Models with One Display

1. Press the selector knob to switch the display to a folder list.
2. Rotate the selector knob to select a folder.
3. Press the selector knob to change the display to a list of files in that folder.
4. Rotate the selector knob to select a file.



Models with Two Displays

1. Select Search.
2. Select a folder.
3. Select a file.

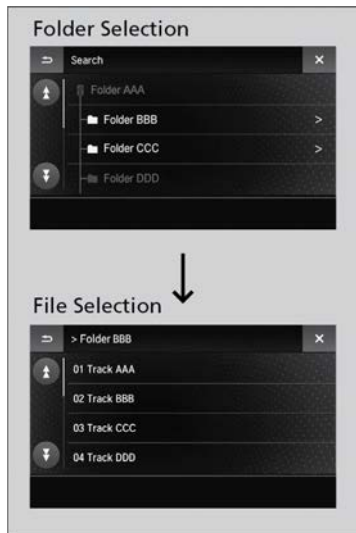

Bluetooth® Audio

Play streaming or stored audio from your compatible phone when it is paired to *Bluetooth*® HandsFreeLink® (see Pairing a Phone). Visit handsfreelink.com (US) to check phone compatibility. Canada customers can phone (855)-490-7351 for any HandsFreeLink® related inquiry. Standard data rates apply with your phone service provider.

■ Models with One Display

Your audio system allows you to listen to music from your *Bluetooth*®-compatible phone. This function is available when the phone is paired and linked to the vehicle's *Bluetooth*® HandsFreeLink® (HFL) system.

Applicable laws may prohibit the operation of handheld electronic devices while operating a vehicle. Launch streaming audio on your phone only when safe to do so.

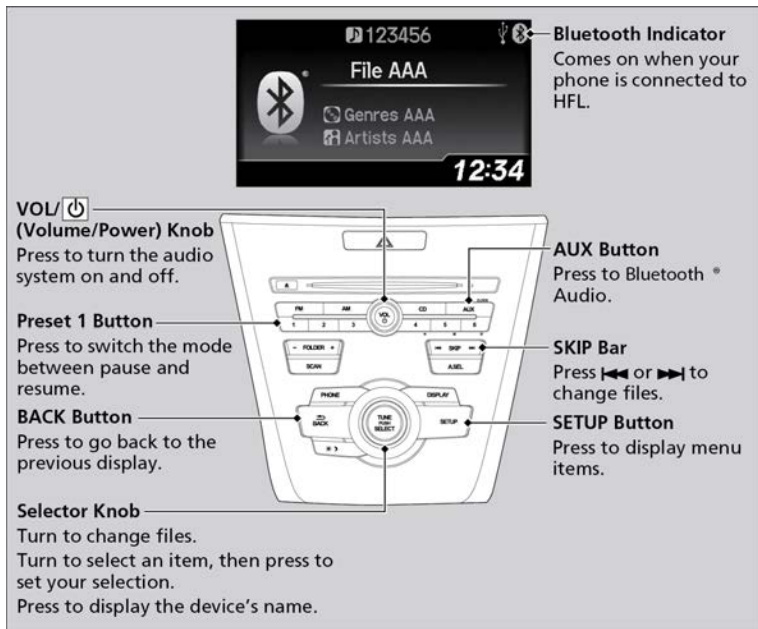

■ Models with Two Displays

Your audio system allows you to listen to music from your *Bluetooth*®-compatible phone. This function is available when the phone is paired and connected to the vehicle's *Bluetooth*® HandsFreeLink® (HFL) system.

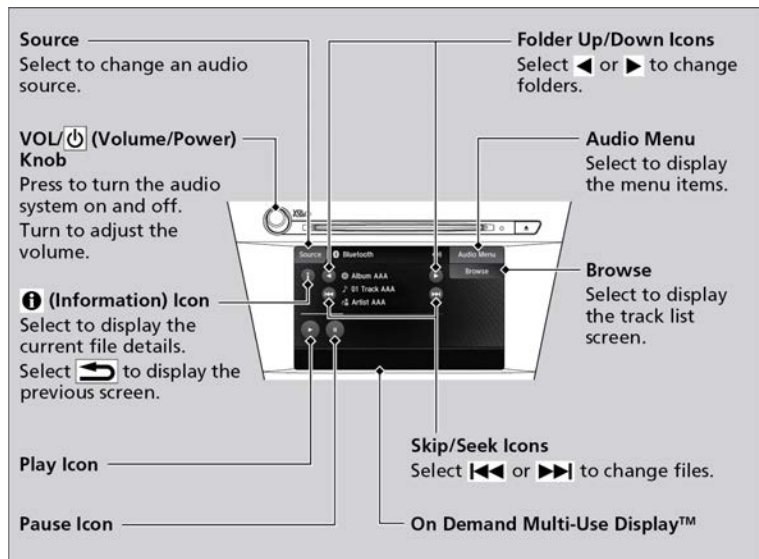

■ Searching for Music

Note:

- Make sure the volume on your phone is properly adjusted.
- You may need to enable additional settings on your phone for playback.
- The resume/pause function and remote audio controls are not supported on all phones.

Models with Two Displays

1. Select Browse.
2. Select a search category (e.g., Albums).
3. Select an item.

The selection begins playing.

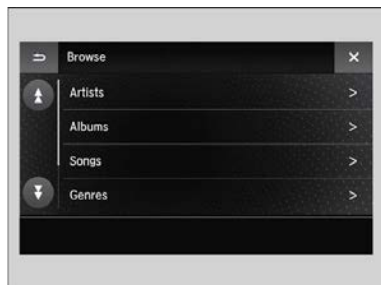

Models with One Display

1. Make sure that your phone is paired and linked to HFL.

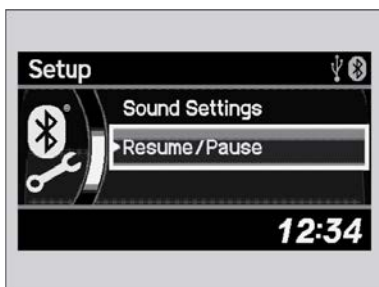

2. Press the AUX button.

If the phone is not recognized, another HFL-compatible phone, which is not compatible for *Bluetooth*[®] Audio, may already be connected.

Compact Disc (CD)

The audio system supports audio CDs, CD-Rs, and CD-RWs in MP3, WMA, or AAC formats. With the CD loaded, select the CD mode.

NOTICE

Do not use CDs with adhesive labels or insert a damaged CD. Inserting these types of CDs may cause them to get stuck inside or damage the audio unit.

Models with One Display

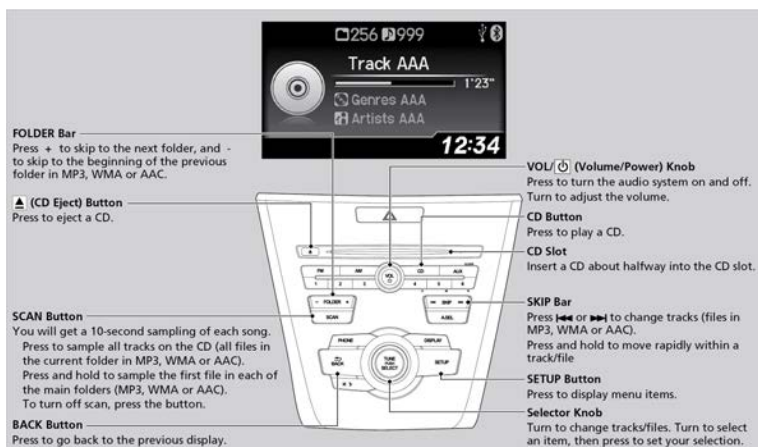

■ Models with Two Displays

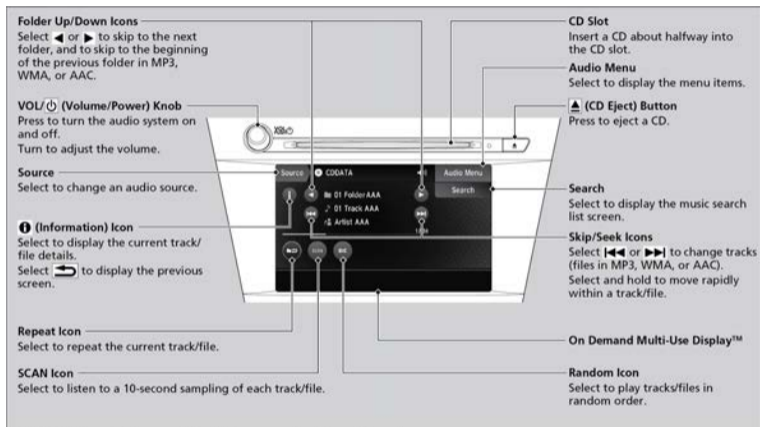

*1: Only AAC format files recorded with iTunes are playable on this unit.